



**CENTRAL INSTITUTE OF MINING & FUEL RESEARCH**  
(CSIR, Ministry of Science & Technology, Govt. of India)  
H.Q.: Barwa Road Campus, Dhanbad – 826 001 (Jharkhand), India

No.CIMFR/PUR/14(3)2007

Date:26.09.2007

**NOTICE INVITING TENDER & EOI**

Director, CIMFR invites sealed EOI & tenders (In two Bid System) for supply, installation and & commissioning of the following stores.

Item No.	Particulars of Item	Qty.
1.	Expression of Interest (EOI) for Rectification of On-line Tele-Monitoring System of Mine Fire Model Gallery.	1 set
2.	Top loading Semimicro (Analytical) Electronic Balance	19 Nos.
3.	Computerised Wire Rope Defectograph / Rope Tester	1 complete set
4.	Expression of Interest (EOI) towards procurement of Ground Penetrating Radar System (GPRS)	1 Unit
5.	Double Beam Atomic Absorption Spectrophotometer.	1 set

**Last Date of Submission : 30.10.2007      Time: Up to 4.00 P.M.**

**Last Date of Opening : 31.10.2007      Time: 10.00 AM onwards**

**Details of the Tender Document is available at [www.cmriindia.nic.in](http://www.cmriindia.nic.in)**

Phone:- 0326- 2388306/2388319  
Fax No: 0326- 2203156/2381210

**Stores & Purchase Officer**



**CENTRAL INSTITUTE OF MINING & FUEL RESEARCH**  
(CSIR, Ministry of Science & Technology, Govt. of India)  
H.Q.:Barwa Road Campus, Dhanbad – 826 001 (Jharkhand), India

No.CIMFR/PUR/14(3)2007

Date:26.09.2007

**NOTICE INVITING TENDR & EOI**

Director, CIMFR invites sealed tenders (In two Bid System) for supply, installation and & commissioning of the following stores.

Item No.	File No.	Particulars of Item	Qty.	T.D. Fee in DD*	EMD in DD/BG/BC
1.	CMRI/PUR-6(48)2006	Expression of Interest (EOI) for Rectification of On-line Tele-Monitoring System of Mine Fire Model Gallery.	1 set	Rs.300.00	NIL
2.	13(2)2CIMFR/56/07-08/PUR	Top loading Semimicro (Analytical) Electronic Balance	19 Nos.	Rs.300.00	Rs.42,000.00
3.	CMRI/PUR-11(11)2007	Computerised Wire Rope Defectograph / Rope Tester	1 complete set	Rs.300.00	Rs.36,000.00
4.	CIMFR/PUR/14(10)2007	Expression of Interest (EOI) towards procurement of Ground Penetrating Radar System (GPRS)	1 Unit	Rs.300.00	NIL
5.	CMRI/PUR/14(2)2006	Double Beam Atomic Absorption Spectrophotometer.	1 set	Rs.300.00	Rs.50,000.00

\* No tender fees are required in case it is downloaded from the site [www.cmriindia.nic.in](http://www.cmriindia.nic.in).

*Note: The Tender Document can be obtained from the Office of the Stores & Purchase Officer, CIMFR, Barwa Road, Dhanbad on written request on payment of the non- refundable and non – transferable tender document fees as stated above in the form of cross Demand Draft issued by a scheduled bank drawn in favour Director, CIMFR, payable at State Bank of India, Hirapur Branch, Dhanbad from 28.09.2007 to 30.10.2007. CIMFR will not be responsible for non- receipt of the Tender Documents due to postal delay/loss in transit. The tender complete in all respect along with EMD should reach to this office on or before 30.10.2007 before 4.00 PM and shall be opened on 31.10.2007 at 10.00 AM onwards in the Meeting Room of CIMFR..*

Tender Documents with detail terms & conditions can be downloaded from our website: [www:cmriindia.nic.in](http://www.cmriindia.nic.in). Tender fees will not be required if it is downloaded from the website up to the tender sale period. The required EMD as stated above in the form of DD or BG must be enclosed in the technical bid failing which the offer will be treated as non-responsive

Director, CIMFR reserve the right to accept or reject in part or in full to any or all the tender without assigning any reason thereof.

Phone:- 0326- 2388306/2388319  
Fax No: 0326- 2203156/2381210

**Stores & Purchase Officer**

# **SCOPE OF WORK :**

## **DETAILED TECHNICAL SPECIFICATIONS**

### **Rectification of on-line tale-monitoring System of CMRI Mine Fire Gallery**

The CMRI mine fire gallery was established in the year 2000-2001. It is equipped with on line tale-monitoring system having 130 sensors. The gallery is 5.86m<sup>2</sup> in cross section and 65.5 m in length. The isometric view of the gallery and details of the instrumentation system are given below.

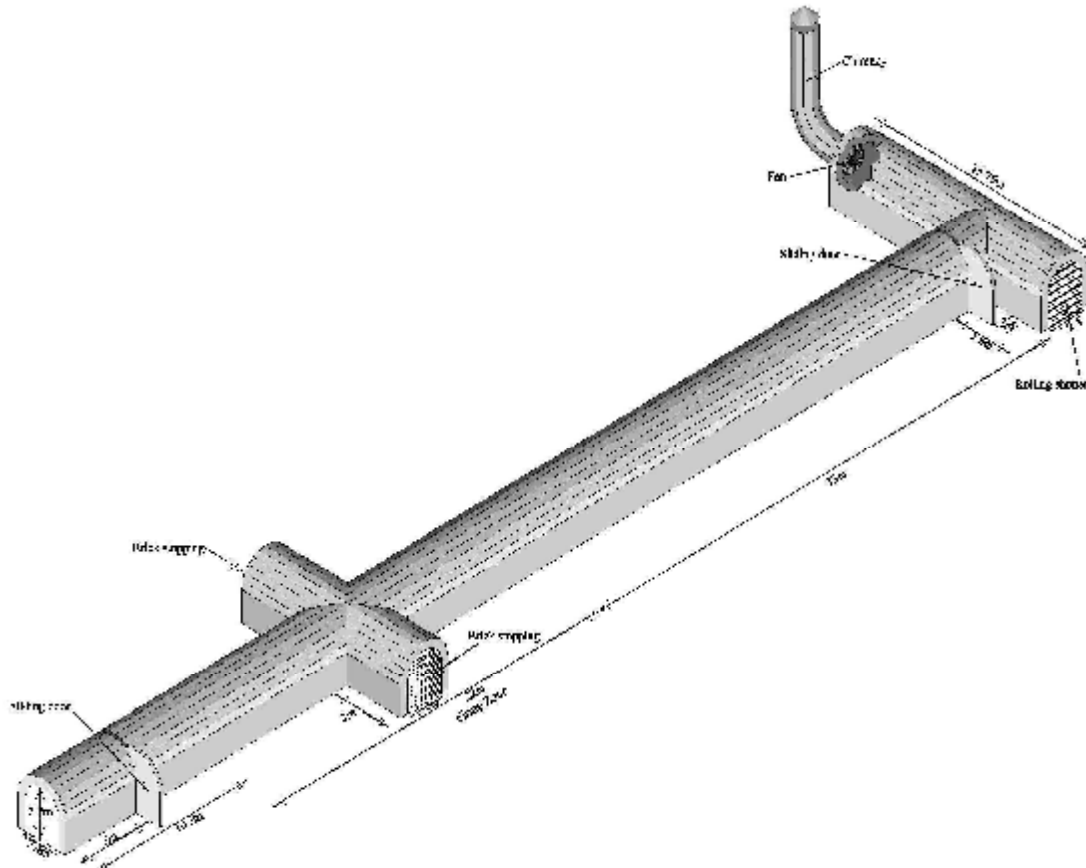

**Isometric view of the gallery**

### **INSTRUMENTATION SYSTEM OF THE GALLERY**

The mine fire model gallery is equipped with state-of-the-art computer aided on-line telemonitoring system. The system consists of 130 sensors with data logger, computer peripheral etc. for continuous monitoring of various parameters like gas concentration, air velocity, and pressure drop across fire zone, temperature, heat flux and suspended particulate matter (SPM) concentration inside the gallery. It was expected that during experimentation the temperature inside the gallery might rise up to 1200°C. Under such condition only temperature sensors can be placed inside the gallery and other sensors have to be placed either in the monitoring room or outer side of the gallery wall with proper cooling arrangements.

For better understanding the entire monitoring system may be described in two heads viz. Instrumentation in the gallery for data generation and Data acquisition system for collection, storage and analysis of data

### 1.1 Instrumentation in the gallery for data generation

The computer aided on-line telemonitoring system comprises of 130 sensors installed in the gallery as well as in the monitoring room. It may be noted that temperature, pressure, velocity, heat flux, smoke density meter sensors are installed at the gallery site with proper cooling arrangements and gas sensors are mounted on a panel in the monitoring room, adjacent to the gallery, for continuous monitoring of CO, CO<sub>2</sub>, CH<sub>4</sub>, O<sub>2</sub> & H<sub>2</sub> gases. Gas samples from inside the gallery will be continuously drawn out by membrane pumps. The gases so drawn would pass through the stack of gas sensors after being cooled and filtered. Altogether five sampling systems are provided at five gas sampling points. Details of sampling and data acquisition system of the instrumentation scheme are shown in the Figure 4.

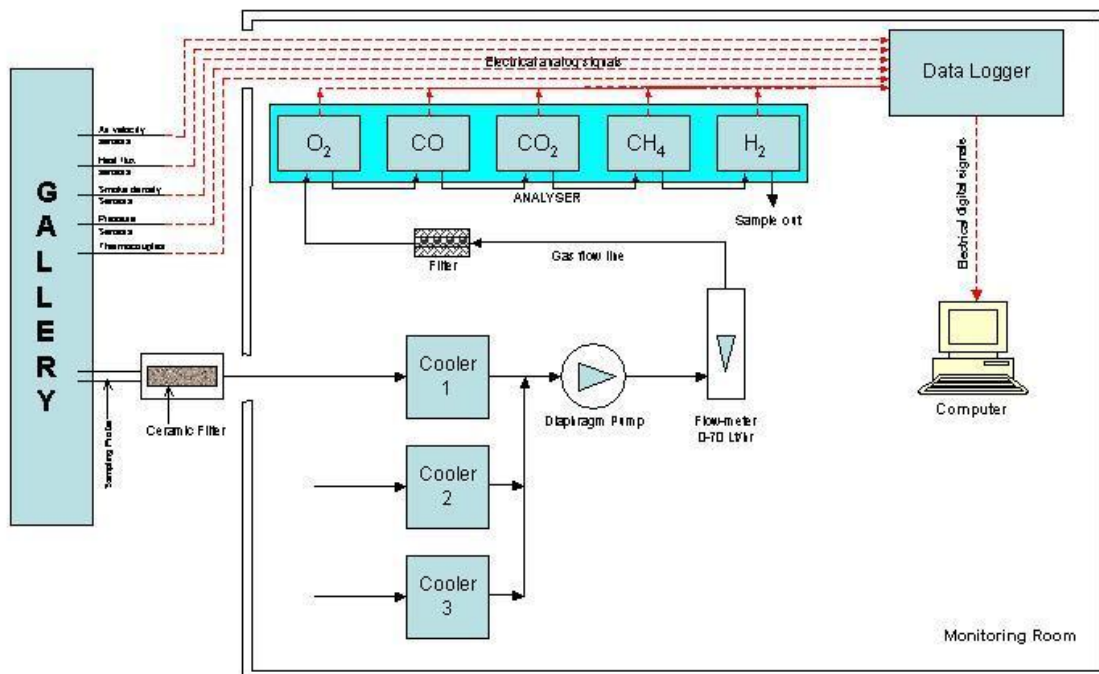
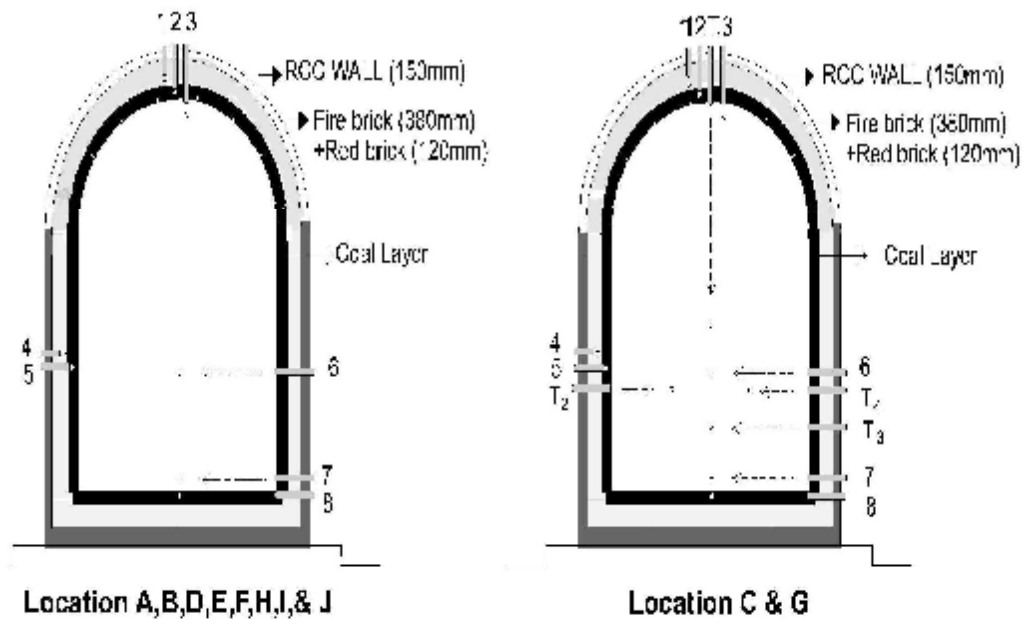

Figure 4 Sampling and Data Acquisition System

To record the temperature distribution along the length of the gallery and to monitor the temperature of coal, brick and air in the roof, sides and floor at about 2.5 m intervals 98 temperature sensors are placed in the gallery. The temperature sensor distribution at different locations in roof, sides in the firing and non-firing zone are depicted in the Figure 4.1



#### Sensor representation:-

- 1== Sensor in brick at the roof of the Gallery
- 2== Sensor in coal at the roof of the Gallery
- 3== Sensor in air at the roof of the Gallery
- 4== Sensor in brick at the side of the Gallery (1.3m from the floor)
- 5== Sensor in coal at the side of the Gallery (1.2m from the floor)
- 6== Sensor in air at the middle of the Gallery (1.3m from the floor)
- 7== Sensor in air at the floor of the Gallery (0.2m from the floor)
- 8== Sensor in coal at the floor of the Gallery
- T1== Sensor in air at the distance of 1.8m from the floor of the Gallery
- T2== Sensor in air at the distance of 1.1m from the floor of the Gallery
- T3== Sensor in air at the distance of 0.6m from the floor of the Gallery
- T4== Sensor in air at the distance of 1.1m from the floor of the Gallery

Figure 4.1 Temperature sensor distributions in the roof, sides and floor at different locations of the gallery

To monitor air velocity inside the gallery a velocity sensor has been installed at the entry of the gallery. Three pressure sensors, two across the firing zone and one at fan house are installed for monitoring of pressure difference across firing zone and fan pressure respectively. Two numbers of heat flux and one smoke density meter are also installed in the gallery for monitoring of heat flux (conductive & convective) and suspended particulate matter (SPM). Details of various monitoring stations and sensor locations along the gallery length are indicated in Figure 4.2 Photograph V and VI show the temperature sensors inside the gallery and view of fan installed in the gallery.

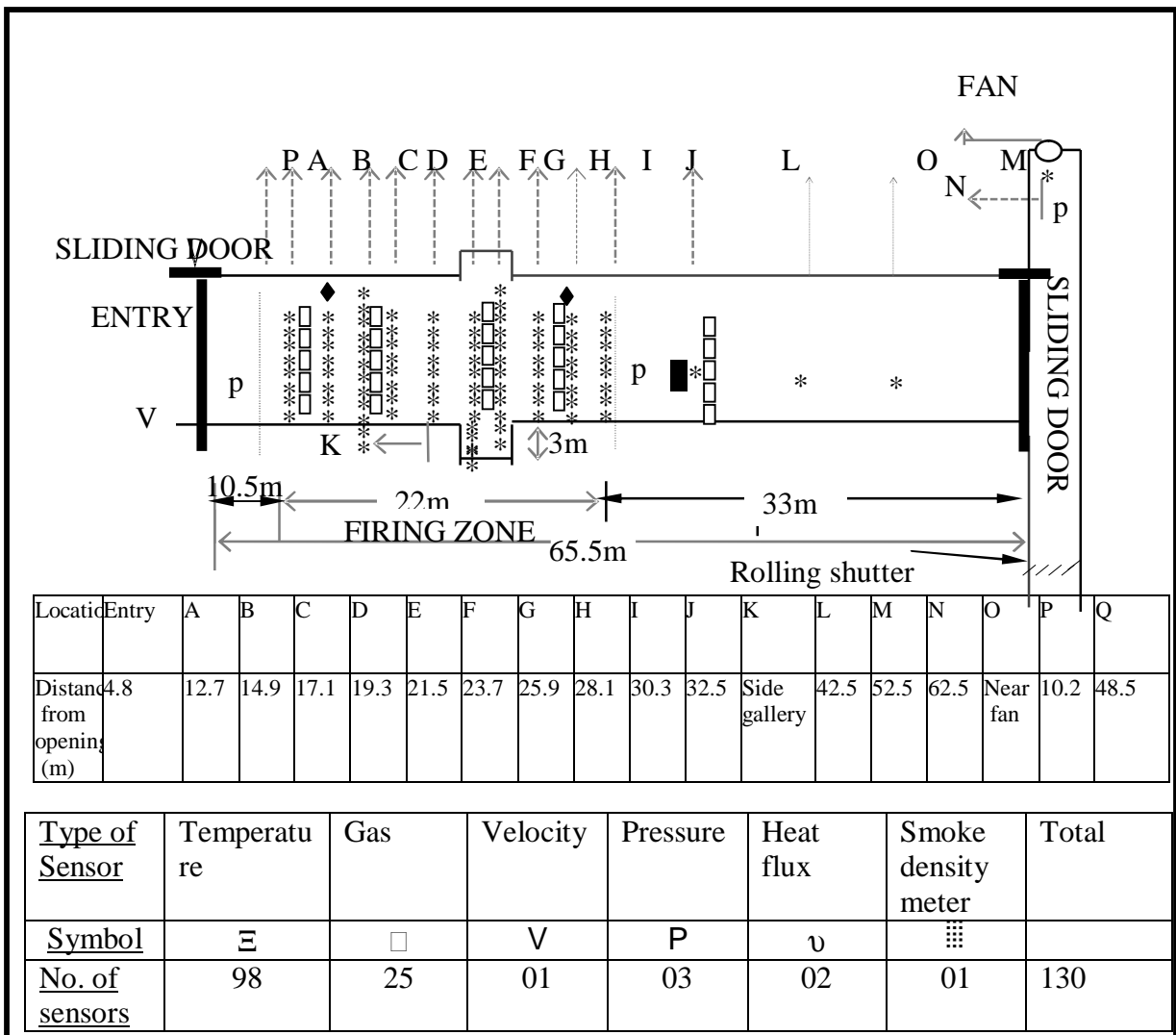

**Figure 4.2** Details of various monitoring stations and sensors location along the gallery length

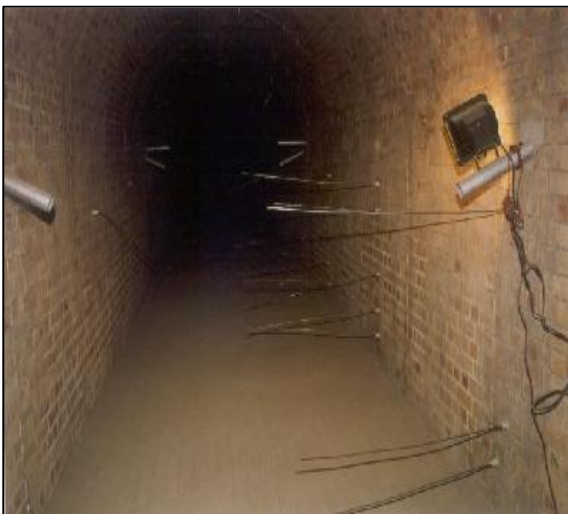

Detail specifications of the equipment/sensors are indicated in the Table 1

**Table 1 Instrument for mine fire model gallery**

S	Name of the equipment	Range	Number	Purpose
1	Temperature sensors Thermocouple chrome-alumel type	-50 to 1200°C	98	For continuous recording of temperature in the gallery
2	Gas Sensors <ul style="list-style-type: none"> <li>IR based CO analysers</li> <li>IR based CO<sub>2</sub> analysers</li> <li>IR based CH<sub>4</sub> analysers</li> <li>Paramagnetic type O<sub>2</sub> analysers</li> <li>Thermal conductivity based H<sub>2</sub> analysers (single pass type)</li> </ul>	0 – 10% Accuracy ± 2% of FS 0 – 20 % Accuracy ± 2% of FS 0 – 100% Accuracy ± 2% of FS 0 – 30% Accuracy ± 0.1% 0 – 5% Accuracy ± 3% of FS	5 Nos. each	For continuous measurement of CO, CO <sub>2</sub> , CH <sub>4</sub> , O <sub>2</sub> & H <sub>2</sub> gases at different sampling points in the gallery
3	I- Heat flux meter  II- Heat flux meter	0 – 5 watt /m <sup>2</sup>  0 – 2 watt /m <sup>2</sup>	1No.  1No.	To measure the conductive and convective heat in the gallery
4	Durag smoke density meter D-R 216 – 40	0 to 500 mg/m <sup>3</sup> (Opacity range 100 %)	1 No.	To measure the SPM on the down stream side of fire and thereby assess opacity
5	Velocity sensor	0.5 to 5 m /sec	1No.	To measure air velocity at the entry of the gallery
6	Differential pressure sensors	0 – 50 mmwg.	3 Nos.	To measure fan pressure and differential pressure across fire zone
7	Axial flow fan Model AF-50 with 30 HP motor	25 m <sup>3</sup> /sec	1 No.	To ensure air supply through the gallery
8	I- Data logger -98 channel II- Data logger-48 channel Model-8030 – MI and 484 port	Mixed universal type	2 Nos.	Collection, storage, analysis and display of data from different sensors
	PC Pentium-IV, 17” colour monitor with CD writer with CITECT SCADA software	RAM – 128 MB, HD – 4 GB, Window 98 operating system with internet modem	1 No.	
	Colour printer, plotter and UPS		1 No.	

## 1.2 Data acquisition system for collection, storage and analysis of data

Data acquisition system consists of data logger, computer peripheral, printer, plotter and software for transmission and analysis of data obtained during experimentation. The detail of the data acquisition system along with sampling system is represented in Figure 4.

As mentioned earlier, about 130 sensors are installed in the mine fire model gallery and signal from these sensors are transmitted to the data logger. Therefore to meet these requirements two data loggers of 98 and 48 channels are provided.

SCADA software on Window-98 operating system for analysis, graphical presentation and fault detection is also incorporated in the PC. The software has the following features.

1. It can store data on daily basis, which can be retrieved in future.
2. It gives digital and graphical representation of individual channel daily and for entire period of the experiment.
3. It can identify each sensor and have alarm generation facility for critical values of different parameters.
4. Outline diagram of tunnel along with location of sensor can be displayed on the monitor along with current reading as and when required (User configurable mimic display).
5. Facility for incorporation of EXPLO program developed by CMRI in the main software to determine the explosibility of gases during experimentation.
6. It can detect the errors like sensor failure, cable fault and any other fault in the system.

**All the sensors installed in the gallery were connected to data-loggers installed in the monitoring room through compensating cables. The online-telemonitoring instrumentation system of the gallery needs to be rectified. Some sensors including data acquisition system are not working properly. Hence complete checking thereafter its rectification and perfect running of online telemonitoring is urgently required. For the better understanding, the details of the system have been provided as above.**

<b>Service Charges @ _____ for each of Two Service Representative to be deputed by us at site – for 80 days.</b>	80 days
<b>Note: The Guest House accommodation on free of cost basis may please be provided.</b>	
<b>Sampling System</b>	
a) Diaphragm Pump – AICPL Make	6 Nos.
b) Sample Gas Cooler – AICPL Make	2 Nos.
c) Coaliscing Filter – AICPL Make	6 Nos.
d) Paper Filter Box – AICPL Make – Box of 100 Papers	6 boxes
<b>Temperature Sensor</b>	
Head	60 Nos.
Thermocouple Complete	20 Nos.
<b>Cable Power &amp; Signal Two Core</b>	500 Mtrs.
<b>Thermocouple Compensating Cable Two Core</b>	500 Mtrs.
<b>Refilling of Calibration Gas Cylinders</b>	5 Nos.
<b>Velocity Sensor</b>	1 No.
<b>DP Sensor</b>	3 Nos.
<b>O<sub>2</sub> Sensor</b>	
Complete O <sub>2</sub> Transducer	1 No.
Spare Electronic components One Lot	1 Lot
<b>CO / CO<sub>2</sub> / CH<sub>4</sub> Sensor</b>	1 Lot
<b>The actual cost of import of M/s Edinburgh Instruments spares cost shall be billed by us with 20% additional handling</b>	
<b>H<sub>2</sub> Sensor</b>	
Detailed repair estimate shall be made after detailed checking & all parts imported shall be billed by us at actual charged with 20% additional handling charges.	1 Lot
<b>Smoke Density Meter &amp; Datalogger</b>	
We shall bill the parts used at actual charges plus 20% handling charges.	1 Lot

# INVITATION OF EXPRESSION OF INTEREST (EOI) CUM REQUEST FOR PROPOSAL (RFP) TOWARDS PURCHASE OF RECTIFICATION OF ON-LINE TELE-MONITORING SYSTEM

---

---

## INTRODUCTION

CIMFR (Central Institute of Mining & Fuel Research) a constituent of Council of Scientific & Industrial Research (CSIR) under the Ministry of Science & Technology, Government of India, devoted to the research and development towards Mines Safety and Energy efficiency and dedicated to the development of modern technology for the country. It is a pioneer Institute under the aegis of Department of Science & Technology fully funded by Govt. of India for the R&D purpose. CIMFR is interested for **Rectification of On-line Tele-monitoring System of CMRI Mine Fire Gallery as per the detailed specification & drawings attached at the technical spec. columns as mentioned in the *Scope of Work***. The CMRI mine fire gallery was established in the year 2000-2001. It is equipped with on line tele-monitoring system having 130 sensors. The gallery is 5.86m<sup>2</sup> in cross section and 65.5 m in length

### D) GENERAL INSTRUCTIONS:

a) All the Interested parties must submit their Expression of Interest with all documentary proof of their technical capabilities and other commercial terms & conditions in a sealed cover clearly mentioning Offer of Expression of Interest for pre qualification of execution of **Rectification of On-line Tele-Monitoring System** *must be addressed and sent to:*

*The Director,  
Central Institute of Mining and Fuel Research,  
Barwa Road, Dhanbad – 826001, Jharkhand, India  
Fax : 0091-326-2202429/2204339/2203156*

E-mail: [dcmrips@yahoo.co.in](mailto:dcmrips@yahoo.co.in), [dcmri@csir.res.in](mailto:dcmri@csir.res.in), Website: [www.cmriindia.nic.in](http://www.cmriindia.nic.in)

**The last date of Submission of Expression of Interest:**

30.10.2007 upto 4.00 PM

**Date of Opening:**

31.10.2007 from 10.00 AM onwards

**Venue: CIMFR Committee Room**

b) Interested bidders must submit their offer for pre-qualification in the proper FORMAT attached to the document.

c) CIMFR will issue road permit if required to the parties. No C&D form will be issued in case this is required. CIMFR is exempted from paying excise duties as per the notification no. 10/97 of Govt. of India. Rates may be quoted accordingly. Necessary EDEC certificate will be issued at the time of requirement.

(d) The firms declared qualified techno-commercially will only be given the chance to bid for the project as decided by D’CIMFR. Director, CIMFR reserves the right to reject the total applications or any part thereof or may award the contract to any firm and may split the work as per requirement without assigning any reason whatsoever.

## (II) DELIVERY SCHEDULED:

As time is the essence of project implementation the work in all respect for example Civil, Fabrication, Electrical, Installation and Commissioning, erection and Demonstration on turnkey basis must be completed within 12 months from the date techno-commercially clear order. Parties must keep this in mind, while submitting their offer.

## (III) AWARD OF CONTRACT:

The work order is scheduled to be awarded by the end of December 2007 and this must be completed within one-year time. The parties submitting their Expression of Interest may contact **Mr. Rudra Pratap Singh, Sct./Member, and Technical Committee CIMFR for further details or visit the site to get more / adequate information to the extent required for preparation and submission of Expression of Interest and may attend the pre-bidding conferencing as per the convenience of the Technical Committee. The Technically qualified bidders will only be given chance of quoting for the Rectification Job.**

## (IV) WARRANTY CLAUSE:

Warranty period should be for a minimum period of **three years onsite comprehensive. Equipments should be under free ONSITE comprehensive warranty for a minimum period of three years from the date of completion of satisfactory installation, testing, commissioning, demonstration and final acceptance of the products.** A satisfactory service during the warranty period is defined as 95% uptime. In case 95% uptime is not provided, the warranty period would be extendable by a period, which is equivalent to the period during which 95% uptime was not provided. **The bidder will also ensure that the spares are available at least for three years after the warranty period for the operation and maintenance of the equipments supplied. The firms giving the warranty offer less than three years must specify the equivalent amount to be charged for additional warranty/per year, which will be added to the price quoted for deciding Lowest Tender. Failing to quote the same will lead to rejection of the bid. This must be strictly complied.**

## (V) PAYMENT TERMS:

### **A. INDIGENOUS:**

- (a) 100% payment will be released after successfully installation, commissioning against 10% to 20% of Performance Bank Guarantee to cover the Warranty period.
- (b) Some advance payment in percentage may also be considered against Bank Guarantee of equivalent amount from a Nationalized Bank/Scheduled Bank along with the purchase order acknowledgement.

### **B. IMPORT:**

In case of import order some percentage of payment will be against dispatch document against LC and major portion of the payment will be admitted after supplying satisfactory demonstration and final acceptance of IO/PL. Any other payment terms suitable to the parties are free to quote.

#### **(VI)\_RATES:**

The price must be quoted for destination including of all charges like Taxes, Duties, Insurance, Packing & Forwarding, and Freight etc. for imported offers. The rate for imported item should be on FOB basis. In case of offers submitted for Ex-works the exact figure of all the extra cost must be mentioned clearly making it FOR destination, failing which offers will be rejected as incomplete.

#### **(VII) LD CLAUSE:**

The LD clause of 01% per week subject to maximum 10% of the order value will be imposed on non-compliance of the order Terms & Conditions. The L.D may further be revised and enhanced as per the discretion of the Competent Authority, CIMFR on violation of the contractual terms of any form. Director, CIMFR reserves the right to go ahead with the procurement of ordered goods from any another vendor without giving any prior notice and cancel the purchase order. In such case, any additional impact on CIMFR over and above that contained in the Purchase Order shall be recovered from the successful vendor from the payment to be made by CIMFR or any of the CSIR Labs. to them towards earlier supplies, EMD or otherwise.

#### **(VIII) STATUTORY REQUIREMENT:**

The bidders responding to our Expression of Interest must conform to the statutory requirement of National and International standard including risk Insurance Coverage, Metal Test Certificate of the plant, Safety Certificate and must comply labour laws of India to avoid any complications. Must mention their CST/JST VAT, TIN No., PAN (copy should be attached).

#### **(IX) EARNEST MONEY DEPOSIT:-**

The parties qualified techno- commercially will have to submit a particular amount of EMD to be decided to D' CIMFR at the time of invitation of bids in the form of Demand Draft/ Bank Guarantee in favour of Director, Central Institute of Mining & Fuel Research, Dhanbad

#### **(X) PERFORMANCE BANK GUARANTEE:**

The successful tenderer will have to furnish an unconditional Performance Bank Guarantee in favour of the Director, CIMFR, Dhanbad valid up to sixty (60) days after the warranty from a Scheduled/Nationalised Bank in India for 10% of the total order value within twenty one (21) days of the placement of order for orders where full payment is to be made on Letter of Credit/Sight Draft or on delivery, failing which the purchase order/contract shall be terminated.

#### **(XI) STANDARD SHOULD BE MAINTAINED:**

The bidders qualified technically for the said project work must ensure the standard to be maintained for the execution of the work in both National/ International level and as well as BIS and ISO codes.

## (XII) PRE-BID CONFERENCING:

CIMFR may require to have a “Pre-Bid Conference” to discuss viability and feasibility of the execution of work on receipt of the EOI from respective bidders. Separate communication will be sent to the eligible and pre-qualified bidders for their visit at CIMFR for the interaction and presentation of record wise with the members of the project team to approach technically specification after arriving threshold level. The eligible firm will have to arrange their visit at CIMFR of their own. However, Guest House accommodation (on charge basis) may be provided to the participating representative of the inviting firms.

## (XIII) JURISDICTION :

All the matters related to the subject is under the jurisdiction of Dhanbad Court, Dhanbad, Jharkhand, India

## (XIV) ARBITRATION :

Except where otherwise provided in the Contract, all questions and disputes relating to the meaning of the specifications, instructions and terms & conditions herein before mentioned and as to the quality of the materials, as to any question, claim, right, matter or thing whatsoever, in any way arising out of or relating to the Contract. Specifications, estimates, instructions, orders

or these conditions or otherwise concerning the works, or the execution of the same whether arising during the process of the work or after the completion or abandonment thereof shall be **referred to the sole arbitration of a person nominated by the Director General, Council of Scientific & Industrial Research, New Delhi**, and if he is unable or unwilling to act to the sole arbitration of some other person appointed by him willing to act as such arbitrator. The submission shall be deemed to be submission to Arbitration under the meaning of the India Arbitration & Conciliation, 1996 or any satisfactory modification or reenactment thereof for the time being in force conclusive and binding on all parties of the Contract. **The venue of the arbitration will be Dhanbad only.**

**In the case of a dispute between the purchaser and a foreign supplier, the dispute shall be settled by arbitration in accordance with provision of clause above. But if this not acceptable to the supplier then the dispute shall be settled in accordance with provisions of UNCITRAL (United Nations Commission of International Trade Law) Arbitration Rules. The venue of the arbitration shall be the place from where the order is issued.**

**(4) Pre qualifying requirements and the documents should be submitted by the interest bidders:**

**I. COMPANY PROFILE:**

- i) Company profile with past experience.
- ii) Audited annually financial Turn over and the copy of balance sheet for last three years.
- iii) The details of the work in progress at present for the similar nature of job with project cost.
- iv) Latest Solvency Certificate from banker issued on or after 01.01.2007.
- vi) Details of the client list with full address and Phone, FAX, email address and name of the contact person along with testimonials.
- vii) Awards and recognizing received by the firm.
- viii) Details of the logistic support.
- ix) ITCC certificate for last three years.

**II. PAST EXPERIENCE**

The firm should have undertaken at least one or two similar nature of work in the recent past ( last three to five years) with the work or value up to two crores, to the satisfaction of the ordered firm.

- III. TECHNICAL KNOW HOW:** The firms must submit details of the technology proposed to be executed for the GPRS systems with brief design subject and drawings if any.
- IV. AUDITED DOCUMENTS:** Certificates related to the formation of their company/firm and its collaboration with the others like Indian Agent.
- V.** Any other assistance to be required from CIMFR while executing the contract must be clearly specified.
- VI.** The details of the pre-requisites to be used and arranged including the area and conditions of the site must be clearly spelt out.
- VII.** Litigation history sheet:
- VIII.** Availability of equipments T&P for the purpose and the infrastructure and the equipments.
- IX.** List of Technical/ managerial key persons, manpower working in the company having experience and expertise in the work on similar nature.
- X.** Any other information in support of EOI desired of the firm.

**PROFORMA****(To be filled by interested bidders)**

1.	Name and detail address of the firm/company/associates/manufacturers with phone/fax/email/website	:	
2.	Status of the Company (Govt/PSU/Limited company/Private/Indian Agent)	:	
3.	Company/ Firms registration number with date	:	
4.	(i) CST/JST number (in case of Indian firm)	:	
	(ii) VAT/TIN number	:	
	(iii) Service Tax registration number	:	
	(iv) PAN numbers (allotted by IT deptt., Govt. of India). Please attach the ITCC of last 3 years.	:	

5.	Establishment details (with qualification and field of specialization). List of Technical/Managerial key persons having expertise in the proposed work.	:	
6.	Experience:  (Please attached separate sheet for the purpose)	:	
7.	Name of the Indian Agent/Associates in case of foreign bidder	:	
8.	Name of Banker with full address, phone, fax number	:	
9.	Certificate from Chamber of Commerce of the origin country (in case of foreign principals:	:	
10.	Technology Proposed (attach separate sheet)		
11.	Details of logistic support		
12.	Awards/recognition		

13.	Any other information in support of EOI		
14.	Details of the pre-requisites for installation of the Machine		
15.	Name & addresses of the clients & testimonials		

Certified that the facts stated above are true to the best of my knowledge and belief.

Signature:

Name :

(of the authorized official of the company with seal)

Date:

Place:

***Note: Please attach separate sheet for the detailed information giving references at Annexures.***

File No.CMRI/PUR-13(2)/CIMFR/56/07-08/PUR		
Sl No.	<b>Top loading Semimicro (Analytical) Electronic Balance</b>	
1.	Weighing Capacity Dual Range (Not Less than)	70g/230g
	Readability	0.01mg/ 0.1mg
	Repeatability less than or equal to	0.03mg/0.1mg
	Linearity ( $\pm$ )	0.04mg/0.2mg
	Response time (average) (For stable and reproducible readout with an accuracy of 5 decimal places)	(Not more than) 12 seconds/ 4 sec.
	Taring	100% full range (0 to maximum capacity)
	Weighing Pan Size (dia)	Minimum 80 mm
	Display	LCD
	Draught-shield	Yes
	Calibration	Internal (built in)
	RS 232 interface connectivity	Yes
	Line Voltage	230V +/- 15%, 50 Hz
	ISO 9000 certified	Yes
	<b>Quantity : 19 Nos.</b>	

<b>Sl No.</b>	<b>File No.CMRI/PUR-11(11)2007</b>
1.	<p><b>Computerised Wire Rope Defectograph / Rope Tester</b></p> <ul style="list-style-type: none"> <li>(a) Complete processing/recording unit with long connecting cable.</li> <li>(b) Sensing head(s) for ropes with diameter range 20-65 mm or higher – two or more magnetic heads may be provided for different range of diameters.</li> <li>(c) Area/local faults detection with provision for measurement of LF, LMA, Distance and speed of rope movement etc.</li> <li>(d) Digital recording facility with memory card and thermal digital recorder.</li> <li>(e) Interfacing hardware, card slot for digital data acquisition and windows based software package for browsing, exporting etc. compatible for Indian PC, Computer upgrade preferable.</li> <li>(f) Printer/Colour Printer</li> <li>(g) Rope length converter</li> <li>(h) Custom carrying and protective cases.</li> <li>(i) Training if needed for tackling problems in the instrument explaining the working and trouble shooting.</li> <li>(j) Operation and Maintenance manual with detail circuit diagrams.</li> <li>(k) The total system should be calibrated and verified properly and the reports should be enclosed with validity period etc.</li> <li>(l) Details of after sales service and support with spares and minimum period of advice/repair/service etc.</li> <li>(m) Latest upgraded model of the instrument with comparatively lesser weight will be preferred.</li> <li>(n) List of users may be provided.</li> <li>(o) Minimum 1 year guarantee/warranty on equipment.</li> <li>(p) Power inverter (standby spares) for better operation (optional).</li> <li>(q) One standby long connecting cable for processing/recording on it (optional).</li> <li>(r) Any other improved feature may also be listed.</li> </ul> <p><i>[Separate Price List of the optional equipment and attachments may be supplied. In addition, principles of operation of the particular equipment should be made clear and the limitations of the equipment will also require to be explained.]</i></p> <p><b>N.B.: Indian Agent may be contacted for future service if required and name of the Indian Agent may be supplied by the Company.</b></p>

## INVITATION OF EXPRESSION OF INTEREST (EOI) CUM REQUEST FOR PROPOSAL (RFP) TOWARDS PURCHASE OF GROUND PENETRATING RADAR SYSTEM (GPRS)

---

---

### INTRODUCTION

CIMFR (Central Institute of Mining & Fuel Research) a constituent of Council of Scientific & Industrial Research (CSIR) under the Ministry of Science & Technology, Government of India, devoted to the research and development towards Mines Safety and Energy efficiency and dedicated to the development of modern technology for the country. It is a pioneer Institute under the aegis of Department of Science & Technology fully funded by Govt. of India for the R&D purpose. CIMFR is interested for supply, installation, erraction, commissioning and successfully demonstration of **Ground Penetrating Radar System (GPRS)**. CIMFR has undertaken an S&T Project entitled “**Delineation of barrier thickness against waterlogged workings in underground coal Mines**” in which it is proposed to delineate barrier thickness in underground coalmines using GPR system to check inundation hazard. One of the objectives of the project is to necessarily increase the penetration range of the radar beyond 30 m, preferably to 60 m or more and to develop an user friendly handheld GPR for use in the underground coal mines.

### SCOPE OF WORK

The scope of work will consists of complete supply, fabrication erraction , installation and commissioning cum demonstration of the GPRS system including its civil structures and design. The system also must conform to the following technical specification and standards.

- It should be designed to withstand mine environment, intrinsically safe according to IS 5780-1980.
- It should be sufficiently high powered system to penetrate 60m depth or more in coal measure strata. It should be portable and user-friendly.
- It should be used conveniently in underground coalmines with semi-automated operation.
- It should have high quality raw digital radar data storage on non-volatile media.
- It should have facility to document the position and time of data collection with Survey Wheel Encoder, DGPS (Differential Global Penetrating System) or otherwise.
- Firm should agree to sign a MOU with CIMFR, India for the implementation of this system.
- The Antennas, containing the Plug-in-Electronics, should be movable over the ground or along a rock/coal face, enabling data to be collected rapidly and large areas to be profiled quickly. Data should stored on internal memory for later up-loading to PC and subsequent processing.
- The time duration for development of GPR and its successful demonstration in Indian Coalmines is 12 months from the date of award of work order.
- Firm should be ready to bear the expenditure towards the travel and other associated expenditure in their host country of visiting Indian Scientists during hardware, software development and data analysis of new GPR system specified as the above or alternatively if they are visiting India for the purpose, they should bear the cost.

## I) GENERAL INSTRUCTIONS:

a) All the Interested parties must submit their Expression of Interest with all documentary proof of their technical capabilities and other commercial terms & conditions in a sealed cover clearly mentioning Offer of Expression of Interest for pre qualification of execution of **Ground Penetrating Radar System having depth of penetration of 60 m or more *must be addressed and sent to:***

*The Director,  
Central Institute of Mining and Fuel Research,  
Barwa Road, Dhanbad – 826001, Jharkhand, India  
Fax : 0091-326-2202429/2204339/2203156*

E-mail: [dcmrips@yahoo.co.in](mailto:dcmrips@yahoo.co.in), [dcmri@csir.res.in](mailto:dcmri@csir.res.in), Website: [www.cmriindia.nic.in](http://www.cmriindia.nic.in)

**The last date of Submission of Expression of Interest:**

30.10.2007 upto 4.00 PM

**Date of Opening:**

31.10.2007 from 10.00 AM onwards

**Venue: CIMFR Committee Room**

b) Interested bidders must submit their offer for pre-qualification in the proper FORMAT attached to the document.

c) CIMFR will issue road permit if required to the parties. No C&D form will be issued in case this is required. CIMFR is exempted from paying excise duties as per the notification no. 10/97 of Govt. of India. Rates may be quoted accordingly. Necessary EDEC certificate will be issued at the time of requirement.

(d) The firms declared qualified techno-commercially will only be given the chance to bid for the project as decided by D’CIMFR. Director, CIMFR reserves the right to reject the total applications or any part thereof or may award the contract to any firm and may split the work as per requirement without assigning any reason whatsoever.

## (II) DELIVERY SCHEDULED:

As time is the essence of project implementation the work in all respect for example Civil, Fabrication, Electrical, Installation and Commissioning, erection and Demonstration on turnkey basis must be completed within 12 months from the date techno-commercially clear order. Parties must keep this in mind, while submitting their offer.

## (III) AWARD OF CONTRACT:

The work order is scheduled to be awarded by the end of September/October 2007 and this must be completed within one-year time. The parties submitting their Expression of Interest may contact Dr. K. K. Singh, Sct., Member, and Technical Committee CIMFR for further details or visit the site to get more / adequate information to the extent required for preparation and submission of Expression of Interest.

#### (IV) WARRANTY CLAUSE:

Warranty period should be for a minimum period of **three years onsite comprehensive.**

**Equipments should be under free ONSITE comprehensive warranty for a minimum period of three years from the date of completion of satisfactory installation, testing, commissioning, demonstration and final acceptance of the products.** A satisfactory service during the warranty period is defined as 95% uptime. In case 95% uptime is not provided, the warranty period would be extendable by a period, which is equivalent to the period during which 95% uptime was not provided. **The bidder will also ensure that the spares are available at least for three years after the warranty period for the operation and maintenance of the equipments supplied. The firms giving the warranty offer less than three years must specify the equivalent amount to be charged for additional warranty/per year, which will be added to the price quoted for deciding Lowest Tender. Failing to quote the same will lead to rejection of the bid. This must be strictly complied.**

#### (V) PAYMENT TERMS:

##### **A. INDIGENOUS:**

- (a) 100% payment will be released after successfully installation, commissioning against 10% to 20% of Performance Bank Guarantee to cover the Warranty period.
- (b) Some advance payment in percentage may also be considered against Bank Guarantee of equivalent amount from a Nationalized Bank/Scheduled Bank along with the purchase order acknowledgement.

##### **B. IMPORT:**

In case of import order some percentage of payment will be against dispatch document against LC and major portion of the payment will be admitted after supplying satisfactory demonstration and final acceptance of IO/PL. Any other payment terms suitable to the parties are free to quote.

#### (VI) RATES:

The price must be quoted for destination including of all charges like Taxes, Duties, Insurance, Packing & Forwarding, and Freight etc. for imported offers. The rate for imported item should be on FOB basis. In case of offers submitted for Ex-works the exact figure of all the extra cost must be mentioned clearly making it FOR destination, failing which offers will be rejected as incomplete.

#### (VII) LD CLAUSE:

The LD clause of 01% per week subject to maximum 10% of the order value will be imposed on non-compliance of the order Terms & Conditions. The L.D may further be revised and enhanced as per the discretion of the Competent Authority, CIMFR on violation of the contractual terms of any form. Director, CIMFR reserves the right to go ahead with the procurement of ordered goods from any another vendor without giving any prior notice and cancel the purchase order. In such case, any additional impact on CIMFR over and above that contained in the Purchase Order shall be recovered from the successful vendor from the payment to be made by CIMFR or any of the CSIR Labs. to them towards earlier supplies, EMD or otherwise.

#### **(VIII) STATUTORY REQUIREMENT :**

The bidders responding to our Expression of Interest must conform to the statutory requirement of National and International standard including risk Insurance Coverage, Metal Test Certificate of the plant, Safety Certificate and must comply labour laws of India to avoid any complications. Must mention their CST/JST VAT, TIN No., PAN (copy should be attached).

#### **(IX) EARNEST MONEY DEPOSIT:-**

The parties qualified techno- commercially will have to submit a particular amount of EMD to be decided to D'CIMFR at the time of invitation of bids in the form of Demand Draft/ Bank Guarantee in favour of Director, Central Institute of Mining & Fuel Research, Dhanbad

#### **(X) PERFORMANCE BANK GUARANTEE:**

The successful tenderer will have to furnish an unconditional Performance Bank Guarantee in favour of the Director, CIMFR, Dhanbad valid up to sixty (60) days after the warranty from a Scheduled/Nationalised Bank in India for 10% of the total order value within twenty one (21) days of the placement of order for orders where full payment is to be made on Letter of Credit/Sight Draft or on delivery, failing which the purchase order/contract shall be terminated.

#### **(XI) STANDARD SHOULD BE MAINTAINED:**

The bidders qualified technically for the said project work must ensure the standard to be maintained for the execution of the work in both National/ International level and as well as BIS and ISO codes.

#### **(XII) PRE-BID CONFERENCING:**

CIMFR may require to have a "Pre-Bid Conference" to discuss viability and feasibility of the execution of work on receipt of the EOI from respective bidders. Separate communication will be sent to the eligible and pre-qualified bidders for their visit at CIMFR for the interaction and presentation of record wise with the members of the project team to approach technically specification after arriving threshold level. The eligible firm will have to arrange their visit at CIMFR of their own. However, Guest House accommodation (on charge basis) may be provided to the participating representative of the inviting firms.

#### **(XIII) JURISDICTION :**

All the matters related to the subject is under the jurisdiction of Dhanbad Court, Dhanbad, Jharkhand, India

#### **(XIV) ARBITRATION :**

Except where otherwise provided in the Contract, all questions and disputes relating to the meaning of the specifications, instructions and terms & conditions herein before mentioned and as to the quality of the materials, as to any question, claim, right, matter or thing whatsoever, in any way arising out of or relating to the Contract. Specifications, estimates, instructions, orders

or these conditions or otherwise concerning the works, or the execution of the same whether arising during the process of the work or after the completion or abandonment thereof shall be **referred to the sole arbitration of a person nominated by the Director General, Council of Scientific & Industrial Research, New Delhi**, and if he is unable or unwilling to act to the sole arbitration of some other person appointed by him willing to act as such arbitrator. The submission shall be deemed to be submission to Arbitration under the meaning of the India Arbitration & Conciliation, 1996 or any satisfactory modification or reenactment thereof for the time being in force conclusive and binding on all parties of the Contract. **The venue of the arbitration will be Dhanbad only.**

**In the case of a dispute between the purchaser and a foreign supplier, the dispute shall be settled by arbitration in accordance with provision of clause above. But if this not acceptable to the supplier then the dispute shall be settled in accordance with provisions of UNCITRAL (United Nations Commission of International Trade Law) Arbitration Rules. The venue of the arbitration shall be the place from where the order is issued.**

**(4) Pre qualifying requirements and the documents should be submitted by the interest bidders:**

**I. COMPANY PROFILE:**

- i) Company profile with past experience.
- ii) Audited annually financial Turn over and the copy of balance sheet for last three years.
- iii) The details of the work in progress at present for the similar nature of job with project cost.
- iv) Latest Solvency Certificate from banker issued on or after 01.01.2007.
- vi) Details of the client list with full address and Phone, FAX, email address and name of the contact person along with testimonials.
- vii) Awards and recognizing received by the firm.
- viii) Details of the logistic support.
- x) ITCC certificate for last three years.

**XI. PAST EXPERIENCE**

The firm should have undertaken at least one or two similar nature of work in the recent past ( last three to five years) with the work or value up to two crores, to the satisfaction of the ordered firm.

**XII. TECHNICAL KNOW HOW:** The firms must submit details of the technology proposed to be executed for the GPRS systems with brief design subject and drawings if any.

**XIII. AUDITED DOCUMENTS:** Certificates related to the formation of their company/firm and its collaboration with the others like Indian Agent.

**XIV.** Any other assistance to be required from CIMFR while executing the contract must be clearly specified.

**XV.** The details of the pre-requisites to be used and arranged including the area and conditions of the site must be clearly spelt out.

**XVI.** Litigation history sheet:

**XVII.** Availability of equipments T&P for the purpose and the infrastructure and the equipments.

**XVIII.** List of Technical/ managerial key persons, manpower working in the company having experience and expertise in the work on similar nature.

**XIX.** Any other information in support of EOI desired of the firm.

**PROFORMA****(To be filled by interested bidders)**

16.	Name and detail address of the firm/company/associates/manufacturers with phone/fax/email/website	:	
17.	Status of the Company (Govt/PSU/Limited company/Private/Indian Agent)	:	
18.	Company/ Firms registration number with date	:	
19	(i) CST/JST number (in case of Indian firm)	:	
	(ii) VAT/TIN number	:	
	(iii) Service Tax registration number	:	
	(iv) PAN numbers (allotted by IT deptt., Govt. of India). Please attach the ITCC of last 3 years.	:	

20.	Establishment details (with qualification and field of specialization). List of Technical/Managerial key persons having expertise in the proposed work.	:	
21.	Experience:  (Please attached separate sheet for the purpose)	:	
22.	Name of the Indian Agent/Associates in case of foreign bidder	:	
23.	Name of Banker with full address, phone, fax number	:	
24.	Certificate from Chamber of Commerce of the origin country (in case of foreign principals:	:	
25.	Technology Proposed (attach separate sheet)		
26.	Details of logistic support		
27.	Awards/recognition		

28.	Any other information in support of EOI		
29.	Details of the pre-requisites for installation of the Machine		
30.	Name & addresses of the clients & testimonials		

Certified that the facts stated above are true to the best of my knowledge and belief.

Signature:

Name :

(of the authorized official of the company with seal)

Date:

Place:

***Note: Please attach separate sheet for the detailed information giving references at Annexures.***

<b>Sl No.</b>	<b>File No.CMRI/PUR/14(2)2006</b>	
	<b>Double Beam Atomic Absorption Spectrophotometer</b>	
1.	System	The basic system should be equipped with absorption and emission capabilities. The system should be computer controlled with a facility to adjust slit width, wavelength, lamp current etc.
	Atomizer	The instrument should be provided with atomizer that should be in separate flame and graphite mode and compartment, but in single unit. The changeover from flame to graphite furnace should be carried out automatically via software. The graphite furnace should be provided with auto sampler and should be permanently aligned and pre-installed with the furnace.
	Lamp System	Minimum 6 lamps position automatic lamp holder with computer controlled lamp selection, its alignment, and automatic optimization of energy using coded lamps.
	Optical System	The optical system should be double beam system using monochromator have a minimum focal length of 270mm and with a grating of 1800 lines/mm. The instrument should have the capability for wavelength of 190 or below – 900 nm preferably using a wide range photomultiplier tube as the detector.
	Back ground correction	The instrument should have a Deuterium lamp based background correction
	Slit Width	The instrument should have the provision for slot width selection of 0.2, 0.5, 1.0 nm with 0.1 nm band-pass for below 400 nm.
	Burner	Burner should be provided for both air/acetylene and nitrous oxide fuel. The ignition, height and direction of the burner should on the application should be automatically adjusted via software.
	Graphite Furnace.	The graphite furnace operation should be completely computer controlled with temperature range of ambient to 3000 degree in the increments of 1 degree. The graphite furnace should be provided with an auto-sampler with minimum 50 samples capacity.
	Cathode Lamps	Cu, Fe, Mn, Cr, Cd, Ni, Co, Pb, Zn, Ca, Mg, Na, K, Al, Si, Hg, Se, As, B, Ba, Be, Bi, Li, P, Ag, Sr, Ti, Sn and Zr should be quoted.
	Hydride Generator	Automatic Hydride / Vapour generation system for trace level analysis of Hg, Se, As etc. This system should operate automatically under PC control and should provide full auto sampling operation.
	Safety Features	The instrument should have safety features for flame ignition, oxidant changeover, flame shut down, flash back arrestor, pressure regulator, flame and pressure sensors etc.
	Accessories	Supporting accessories like Computer, Printer, Exhaust Hood, Air Compressor, Air-acetylene Regulator & Nitrous Oxide Regulator, UPS.
	Training	Training of Two Scientists should be provided including to and fro journey fare, fooding, lodging free of cost.
Quantity	1 Set	

# Central Institute of Mining & Fuel Research

Erstwhile Central Mining Research Institute  
(Council of Scientific & Industrial Research)  
Barwa Road Campus, Dhanbad –826001 (Jharkhand), INDIA

---

## **COMMERCIAL TERMS & CONDITIONS**

### **Important Notice**

The Commercial Terms & Conditions is given in five different sections, which may please read carefully before submitting the tender. Any deviation and non-compliance of the terms & conditions must be written clearly. An incomplete offer and late bids are liable to be ignored and rejected. To aid the Bidders in submitting complete offers, a Check List is included in the bid document. The bidders must fill this and submit along with their offer in their own interest to avoid rejection of their tender.

### **Request For Proposal (RPF)**

1.NIT No.

CIMFR/PUR/14(3)2007

1.Last Date for Submission of Bid :

30.10.2007 upto 4.00 PM

2.Date of Opening of Tender(only Technical Bid in case of Double Bid System)

31.10.2007 at 10.00 A.M

3.Date of Opening Financial Bid wherever applicable : TENDERERS WHOSE TENDERS ARE  
FOUND TECHNICALLY SUITABLE

# **SECTION - I**

## **INVITATION FOR THE BIDS**

Sealed tenders are invited under **Two Bids System** 1. Technical-Commercial Bid and 2. Financial Bid for the products mentioned in our Global / Open Tender Notice required to be supplied, installed, commissioned and demonstrated at CIMFR, Dhanbad. **Technical- Commercial Bid and Financial Bid should be identical in all respects except that the Technical-Commercial Bid should have blank space at the place where prices have been indicated in the Financial Bid.**

Tenderers are requested to submit their tenders in three separate envelopes 1. EMD Envelope, 2. Technical-Commercial Bid Envelope and 3. Financial Bid Envelope duly sealed and super scribed with "Tender No. and Description of item" strictly as per our Technical specifications and Terms and Conditions.

**Technical-Commercial Bid** should consist of:

1. Technical specifications being offered by the firm of Tender Documents along with Brochures and literature giving all features.
2. Certificate of Registration of firm
- 3. Authorisation Letter from the manufacturer to quote and submit tender.**
4. Certificate of valid Authorised Distributorship/Dealership/Retailer ship from the manufacturer.
5. Latest Income Tax Clearance Certificate
6. Certificate of Central Sales Tax/Local Sales Tax Registration No. Authorised Service Provider Certificate from the Manufacturer only.
- 7. Photocopy of Warranty Service Provider Agreement between the manufacturer and the Service Provider.**
8. Clients list along with addresses, Telephone Nos., Fax Nos., Contact persons. Product supplied, Qty. supplied, Performance Certificates/Bench marking of the equipments by recognized National/Institutional/ Govt. organization like Department of Electronics.
9. Last Audited Balance Sheet of the firm.
10. Maintenance Infrastructure Facilities including addresses, Telephone No. of Service Centre.
11. Photocopy duly attested of Certificate of compulsory enlistment of Indian Agents of Foreign Principals with DGS&D if quoting on their behalf. Date of enlistment must be before the date of opening of tenders.
12. Details of Equipments supplied of identical or similar nature to other CSIR Labs/Institute for the preceding three years along with the prices eventually or finally paid.

### **Commercial Terms :**

- a. Percentage rate of CST/LST, Octroi, freight and forwarding charges, handling charges, loading/unloading charges, any other tax/charge as applicable should be clearly mentioned. The offers indicating "Taxes as applicable" or "Taxes inclusive" may be rejected.
- b. Validity of Quotation
- c. Delivery Period
- d. Payment Terms
- e. Warranty
- f. Training
- g. Discount
- h. Terms of Delivery
- i. Post Warranty AMC
- j. Performance Security Deposit
- k. Liquidated Damages
- l. Installation, testing and commissioning charges
- m. Percentage of Agency Commission in case of imports.
- n. Agency Commission should be included in the FOB Price and will be paid to the Indian Agents if registered with DGS&D.
- o. Gateway Airport in case of shipment from abroad
- p. Beneficiary Bank and SWIFT No. in case of imports

**Financial Bid** should consist of:

**Basic Price** in case of indigenous supply/FOB price in case of imports

**Commercial Terms**

a. Percentage rate of CST/LST, Octroi, freight and forwarding charges, handling charges, loading/unloading charges, any other tax/charge as applicable should be clearly mentioned. The offers indicating "Taxes as applicable" or "Taxes inclusive" may be rejected.

b. Validity of Quotation

c. Delivery Period

d. Payment Terms

e. Warranty

f. Training

g. Discount

h. Terms of Delivery

i. Post Warranty AMC

j. Performance Security Deposit

k. Liquidated Damages

l. Installation, testing and commissioning charges

m. Percentage of Agency Commission in case of imports.

Agency Commission should be included in the FOB Price and will be paid to the Indian Agents if registered with DGS&D.

n. Gateway Airport in case of shipment from abroad

o. Beneficiary Bank and SWIFT No. in case of imports

The bids complete in all respects addressed to the Director, CIMFR should reach at the following address **latest by 4.00 PM on : 30.10.2007**

—  
**Central Institute of Mining & Fuel Research**  
**Erstwhile Central Mining Research Institute**  
**(Council of Scientific & Industrial Research),**  
**Barwa Road Campus, Dhanbad -826001, JHARKHAND, INDIA**  
Tele: 0091-0326-220-3156  
Fax: 0326-2203156,2202429  
STD CODE: 0326

**The Tenders (Technical Bids only wherever applicable) will be opened in this Office at 10.00 A.M hours on 31/10/2007 in the presence of Bidders (only one representative of the firm) who is willing to participate in the tender and whose EMD is in order.**

## **SECTION - II**

### **INSTRUCTION TO BIDDERS**

#### **1. Scope of Work:**

Supply installation, testing, commissioning, demonstration and training in the usage and administration of procurement of products mentioned in our Open Tender Notice.

#### **2. Bidders:**

The invitation for Bid is open to all Indian Original Equipment Manufacturers / Authorized Distributors/Authorized Dealers/Authorized Retailers/Foreign Manufacturers or suppliers directly/authorized Indian Agents who are registered with DGS&D as authorized Indian Agent of Foreign Supplier under the Compulsory scheme of Ministry of Finance. In case Indian Agents submit their tender or forward the tender of Foreign Supplier without DGS&D Registration Certificate, the tender will not be considered. In such cases the tender must be submitted by Foreign Manufacturer/Supplier directly to CIMFR, then the tender of Foreign Manufacturer/Supplier will only be considered and CIMFR will deal directly with the Foreign Manufacturer/Supplier.

#### **3. Cost of Bidding:**

The bidders shall bear all costs associated with the preparation and submission of its bid and CIMFR will in no case be responsible or liable for these costs regardless of the conducts and the outcome of the bidding process.

#### **4. The Bidding Documents:**

The goods and services required, bidding procedures and contract terms are prescribed in the bidding document. In addition to the invitation for the bids, the bidding document includes:

- a) Instruction to bidders
- b) Schedule of requirements
- c) Technical Specifications
- d) Terms & Conditions
- e) Bid form and price schedule

The bidder is expected to examine all instructions, forms, terms and conditions in the bidding document. Failure to furnish all information required or submission of bid not substantially responsive to the bidding documents in every respect will be at the bidder's risk and may result in rejection of its bid.

#### **5. Preparation of bids:**

The bids are to be submitted in three separate sealed envelopes

- a) Earnest Money Deposit
- b) Technical-Commercial Bid
- c) Financial Bid

#### **6. Submission of Bids :**

##### **a) Sealing and Marking of Bids**

- i) The bids shall be submitted in three separate sealed envelopes addressed to The Director, Central Institute of Mining & Fuel Research , Barwa Road, DHANBAD-826001 JHARKHAND, INDIA which shall be marked as "EMD", "Technical-Commercial Bid" and "Financial Bid" mentioning Tender Number, Description of Item and Date of Opening and all the three envelopes should be put inside the big envelope.
- ii) The Envelopes shall indicate the name and address of the bidder to enable the bid to be returned unopened in case it is declared late and delayed.

Telex, cable, facsimile and unsigned bids will not be considered and rejected.

## **b) Deadline for submission of Bids**

i) Bids must be received by CIMFR at the address given in Section-I not later than the time and date specified on the cover page. In the event of the specified date for the submission of bids being declared a holiday for CIMFR, the bids will be received up to the appointed time on the next working day.

ii) The Director, CIMFR may at his discretion extend the deadline for submission of bids by amending the bid documents, in which case all rights and obligations of the purchaser and bidders previously subject to the deadline will thereafter be subject to the deadline as extended.

## **c) Late Bids**

Any bid received after the deadline for submission of bids prescribed by CIMFR will be rejected and/or returned unopened to the bidder.

## **d) Bid Opening and Evaluation**

### **i) Opening of Technical Bids by Purchaser**

The Purchaser will open all Technical-Commercial Bids, if the EMD, is submitted as per requirement in the presence of bidders' representatives who choose to attend, at the time, on the date and venue indicated in Section-I. The bidders' representatives present there, shall sign a register evidencing their attendance. In the event of the specified date of the bid opening being declared a holiday for the Purchaser, the bids shall be opened at the appointed time and location on the next working day.

### **e) Clarification of Bids**

i) During evaluation of the bids, the purchaser may at his discretion ask the Bidder for clarification of bids. The request for clarification and the response shall be in writing and no change in price or substance of the bid shall be sought, offered or permitted.

ii) No Bidder shall contact the Purchaser on any matter relating to its bid from the time of the bid opening to the time the contract is awarded. If the Bidder wishes to bring additional information to the notice of the Purchaser, it should be done in writing.

iii) Any effort by a Bidder to influence the Purchaser in its decisions on bid evaluation, bid comparison or contract award decision may result in rejection of the Bidder's bid.

### **f) Evaluation of Technical Bid**

i) Prior to the detailed technical evaluation the purchaser will determine the substantial responsiveness of each bid to the Bidding Documents. A substantially responsive bid is one that conforms to all the terms and conditions of the Bidding Documents without material deviations.

ii) A bid determined as not substantially responsive will be rejected by the purchaser and may not subsequently be made responsive by the Bidder by correction of the non-conformity.

iii) All the vendors will have to bring their equipment/machine for testing and technical evaluation/bench marking as and when asked for, if required. Separate communication will be sent in this regard.

The bidders short listed by the purchaser based on evaluation of their technical bids may be called for detailed discussion including presentation of their equipment system to a team selected by the purchaser for the purpose, at a specified date, time and venue, if needed.

### **g) Opening of Financial Bids**

i) The purchaser will open the financial bids of only those bidders, which are found to be technically qualified to undertake the job. The time, date and venue of opening of financial bids will be intimated to these technical qualified bidders only.

ii) The Financial Bids of the technically qualified bidders shall be opened in the presence of their representatives, who are willing to participate, on the specified date, time and venue.

#### **h) Evaluation and Comparison of Bid**

i) The comparison shall be of all inclusive prices of goods, inclusive of all costs as well as taxes paid or payable and the warranty period asked for.

ii) Arithmetical errors will be rectified on the following basis: if there is a discrepancy between the unit price and the total price that is obtained by multiplying the unit price and quantity the unit price shall prevail and the total price shall be corrected. If the supplier does not accept the correction of errors, its bid will be rejected. If there is a discrepancy between words and figures, the amount in words will prevail.

iii) Bidders shall state their bid price for the payment schedule. Bids will be evaluated on the basis of this base price. Bidders are however, permitted to state an alternative payment schedule and indicate the reduction in bid price they wish to offer for such alternative payment schedule. The purchaser may consider the alternative payment schedule offered by the selected Bidder but it may not be binding on purchaser.

#### **i) Placement of Purchase Order**

The purchaser will place the purchase order on the successful bidder whose bid has been determined to be substantially responsive and has been determined as the best evaluated bid provided further that the bidder is determined to be qualified to perform the contract satisfactorily.

## SECTION - III

### TERMS & CONDITIONS

**1. Submission of Tenders:** Sealed tenders must be submitted in an envelope duly super scribing "Tender/File Ref.No., Description of item and Date of Opening" addressed to Director. Central Institute of Mining & Fuel Research, Barwa Road, Dhanbad - 826001 JHARKHAND, INDIA in the Tender Box kept in the Office of the Stores & Purchase Officer, CIMFR, **latest by upto 4.00 PM on 30.10.2007 positively. Request for extension of submission date of tenders will not be considered.**

**2. Late/delayed tenders :** Late/delayed tenders due to any reason whatsoever will not be accepted / considered at all under any circumstance.

**3. Opening of Tenders:** The tenders received will be opened at **10.00 A.M.** on **31.10.2007** in the presence of the authorised representatives, if any, of quoting firm (one member only) at this office. **Request for extension of opening date of tenders will not be considered.**

**4. Earnest Money Deposit:** Tenderers shall have to deposit EMD of amount mentioned in our Global / Open Tender Notice in **Indian Rupees** or in equivalent amount in foreign currency in the form of Crossed Demand Draft/BG only in favour of Director. CIMFR, Dhanbad, issued by Scheduled/Nationalised Bank payable at Dhanbad, India, along with their tenders (with Technical Bid only). **Tenders received without earnest money will not be entertained/ considered at all and rejected summarily. Tenders received along with EMD in the form of Cheque/Cash will not be accepted/ considered and rejected.**

**Firms registered with DGS&D and NSIC may be exempted from payment of EMD if the product being quoted is actually manufactured by them and the product is registered with these agencies. Firms registered with these agencies selling products of other companies and not manufacturing the products being quoted by them are not allowed exemption from payment of EMD. Firms are to submit a legible photocopy duly attested, of Registration Certification of the products manufactured and registered with DGS&D and NSIC for availing EMD exemption before opening of Technical-Commercial Bids, otherwise tender submitted by them will not be considered and rejected summarily.**

**5. Forfeiture of EMD:** The earnest money deposited (EMD) will be forfeited if the vendor withdraws or amends, impairs and derogates from the tender in any respect within the period of validity of tender or fails to furnish the Performance Security Deposit as per Clause No. 6 - Performance Security Deposit mentioned below.

**6. Performance Security Deposit:** The successful tenderer will have to furnish an unconditional Performance Bank Guarantee in favour of the Director, CIMFR, Dhanbad valid up to sixty (60) days after the warranty from a Scheduled/Nationalised Bank in India for 10% of the total order value within twenty one (21) days of the placement of order for orders where full payment is to be made on Letter of Credit/Sight Draft or on delivery, failing which the purchase order/contract shall be terminated.

b. The successful tenderer will have to furnish an unconditional Performance Bank Guarantee in favour of the Director, CIMFR, Dhanbad valid up to sixty (60) days after the warranty from a Scheduled/Nationalised Bank in India for 10% of the total order value before the release of final payment where payment is to be made on satisfactory supply, installation, testing, commissioning, demonstration and final acceptance of the products.

**7. Refund of Performance Security Deposit:** The Performance Security Deposit will be returned to the successful vendor after sixty days from the date of the completion of warranty period and no interest would be paid thereon.

**8. Warranty:** Equipments should be under free ONSITE comprehensive warranty for a minimum period of three years from the date of completion of satisfactory installation, testing, commissioning, demonstration and final acceptance of the products. A satisfactory service during the warranty period is defined as 95% uptime. In case 95% uptime is not provided, the warranty period would be extendable by a period which is equivalent to the period during which 95% uptime was not provided. **The bidder will also ensure that the spares are available at least for three years after the warranty period for the operation and maintenance of the equipments supplied. The firms giving the warranty offer less than three years must specify the equivalent amount to be charged for additional warranty/per year which will be added to the price quoted for deciding Lowest Tender. Failing to quote the same will lead to rejection of the bid. This must be strictly complied.**

**9. Custom Duty and Excise Duty:** Our Institution is eligible for payment of concessional Custom Duty and exempted from payment of Excise duty.

a) In case, the tenderers are Indian Agents of the foreign suppliers and quoting prices on behalf of their foreign principals must enclose the proof of compulsory enlistment with DGS&D. Date of enlistment must be before the date of opening of tenders. Tenders of agents not enlisted with DGS&D will be ignored and summarily rejected. The compulsory enlistment of Indian Agents of foreign principals with DGS&D is of general nature and does not confer on the Indian Agents the status of a supplier registered with DGS&D.

b) In case, the prices are quoted in foreign currency, it must be on FOB price. Indian Agency Commission/Technical Service Charges, if any, must also be shown separately and shall be payable in India in Indian Rupees only if the Indian Agent is registered with DGS&D. Kindly indicate Indian Agent's address, their kind of services and percentage Agency Commission (which will be reduced from invoice and paid in Indian Rupees Only). Also quotation should indicate whether Agency Commission is included / excluded in the FOB price.

c) In case of Domestic, the offer should contain the basic price and percentage of Excise Duty separately since we are exempted from payment of Excise Duty.

**10. Prices:** The price quoted should clearly mention whether

- a) FOR destination /Dispatching Station by registered road transport
- b) FOR free delivery at this office Stores including Packing & Forwarding, freight, insurance charges, etc.
- c) Where there is no mention of the above, the offers will be rejected as incomplete.
- d) In case of Imports, the quotation should be for FOB price only.

**11. Taxes:** The percentage rate of sales tax, resale tax, duties/levies and any other charges etc, should be clearly indicated in the tender, wherever chargeable. The packing charges must be included in the rates. **CIMFR is not authorized to issue C/D Forms.** However, the concessional rate of central sales tax is admissible to Research Institutions from certain States is also applicable to this Institute and necessary Concessional Sales Tax Certificate will be issued. The supplier should submit documentary proof while claiming octroi, naka etc. charges.

**12. Annual Maintenance Contract:** After the expiry of warranty period, ONSITE Comprehensive Maintenance Contract may be entered into for which the Annual Maintenance Contract (AMC) charges should invariably be quoted in terms of percentage (%) of cost on the exact amount inclusive of all taxes and duties of the product to be supplied.

Satisfactory services during AMC period is defined as 95% uptime. In case 95% uptime is not provided the AMC period would be extendable by a period which is equivalent to the period during which 95% uptime was not provided.

Response Time : Should be four hours

Preventive Maintenance: Tenderers should provide at least one preventive maintenance service every month during the AMC period.

**13. Training:** Tenderers should provide free training on the complete operation and care of the equipment and Software Packages to be supplied on mutually agreed terms.

**14. Validity of Tender:** The quotations shall be valid for a minimum period of **One Hundred Eighty (180) days from the date of opening of tenders.**

**15. Delivery:** Equipment may be delivered between 11.00 A.M. to 04.00 P.M. on all working days i.e. Monday to Friday at our Stores Section only.

**16. Payment - Indigenous Supplier:** Payment shall be made after delivery, satisfactory installation, testing, commissioning, demonstration and final acceptance of the ordered items by the user department, through an Account Payee cheque drawn on State Bank of India, Hirapur Branch, Dhanbad-826001 (Jharkhand), India within thirty (30) days from the date of submission of the bill. Bill(s) in triplicate duly pre-receipted with Rs.1/- revenue stamp will have to be presented for claiming payments.

**17. Liquidated Damages:** The LD clause of 01% per week subject to maximum 10% of the order value will be imposed on non-compliance of the order Terms & Conditions. The L.D may further be revised and enhanced as per the discretion of the Competent Authority, CIMFR on violation of the contractual terms of any form. Director, CIMFR reserves the right to go ahead with the procurement of ordered goods from any another vendor without giving any prior notice and cancel the purchase order. In such case, any additional impact on CIMFR over and above that contained in the Purchase Order shall be recovered from the successful vendor from the payment to be made by CIMFR or any of the CSIR Labs. to them towards earlier supplies, EMD or otherwise

**18 S.T. Registration No./ITCC/Distributorship/Dealership/Service Provider Certificates:**

Tenderers must attach a legible photocopy of the following documents positively along with their tenders.

- i) CST/Local Sales Tax Registration Certificate.
- ii) Latest Income Tax Clearance Certificate.
- iii) Authorised Distributorship/Authorised Dealership/Authorised Retailership/Authorised Service Provider Certificate from the manufacturers.

**19. Environmental conditions for the installation of equipments:** Tenderers should specify minimum environmental needs for installation of their Equipments such as air-conditioning specifications, power supply specifications including any special requirements like voltage regulators, etc.

**20. Software installation:** Tenderers should clearly specify the minimum hardware requirements for the installation of Software Packages positively.

21. Tenderers should note that they should offer their best products pertaining to Technical specifications given.

22. Tenderers should clearly indicate whether they are Original Equipment Manufacturers or authorised distributors/dealers/suppliers on behalf of manufacturers. Brand names & Model Nos. of all equipments and components offered should necessarily be mentioned.

23. Tenderers should furnish the experience of their organization in the area of manufacturing and/or supply of similar equipment.

**24. Tenderers should have a well established Office and Service and Support Centre in Kolkata / Dhanbad, India,** managed by qualified maintenance professionals along with documentary evidence to be attached with their tenders.

25. Tenderers should indicate the names (along with addresses, Telephone nos., Fax No., Contact person, dates of supply, etc.) of various Government, Public Sector Departments and other organizations where they have supplied and installed the similar equipments and are duly maintaining them.

26. Tenderers should furnish all details of Performance Certification/Bench marking of their Equipments by recognized National/International Institutes Govt. Organizations like D.O.E. (Dept of Electronics), etc as applicable.

27. All prices shall be quoted clearly both in figures and words duly taking into account all concessions provided by the Govt. of India as on the date of tender. In case of discrepancy in Unit and Total prices, unit price shall be taken to be final price for the purpose of calculations.
28. Tenders incorporating additional conditions are liable to be rejected.
29. Complete details including final specifications of the equipments offered/quoted should be furnished along with brochures/literature mentioning all features.
30. Tenderers should indicate whether they are the OEMs/. Authorised Distributors/Authorised Dealers/Authorised Retailer of the equipments offered and have valid license to sell Equipment.
31. Tenderers will also indemnify CIMFR against all possible damage due to any Copyright violation by them.
- 32 Only legal and authorised copy of Software Packages with all original manuals, installation and performance guide, etc. complete in all respects are required to be supplied.
33. Tenderers will replace equipments in toto, in case of any malfunctioning or other similar problems arise after supply of the equipment.
34. Equipment supplied will include all Operational and Maintenance Manuals, tutorials, reference manuals, installation and performance guide, etc. complete in all respects. Connecting cable and/or any other part/device which is essentially required for making the equipment operational is required to be supplied along with the equipment and n additional cost.
35. Printed conditions of the tenders shall not be binding on CIMFR.
36. CIMFR is an R&D organization under CSIR, Ministry of Science & Technology, Govt. of India. Therefore it is requested to **quote concessional rates applicable to the R&D organizations since the equipment is required for research purposes.**
37. Offers for stores vaguely described as "Best Indian Make", "Foreign Make" will be ignored while considering the tenders.
38. Details of Equipments supplied to CSIR Labs/Institutes: The tenderers who have supplied identical or similar equipment to other CSIR Labs/Institutions have to furnish the details of such supplies for the preceding three years along with the prices eventually or finally paid positively.
- 39. Responsibility:** The responsibility lies with the successful tenderer, if any damage or loss to the property of the Institute occurs while undertaking and executing the contract.
- 40. Shortage of Supplies:** Suppliers will have to make the good the shortages, if any, which is revealed after opening the packages. The Stores, which are spoiled/damaged during transit due to faulty packing will have to be replaced by the suppliers. The product should have warranty for workmanship, performance and service for a minimum period of twelve months from the date of acceptance of replacement of spares/parts during warranty period. The replacement should be done free of all costs including to and fro Air Freight, packing, forwarding and insurance charges.
- 41. Defects and Liability Period:** Thirty six months from the date of virtual completion, installation and commissioning of the equipments as certified by CIMFR, Dhanbad, India.
- 42. Damage and Unaccepted supply :** The material found to be damaged and declared rejected should be collected by you at your risks and costs within 21 days from the date of intimation by CIMFR, otherwise ground rent will be charged.

In addition to the Terms and Conditions mentioned above, Terms and Conditions for the items offered from abroad are as follows:

43. The detailed specifications of the material offered should be given. Relevant technical Literature and descriptive catalogue / pamphlet should also be attached with the offer.

44. **FOB Price only to be indicated.** Other charges applicable to be indicated separately.

**45. INSURANCE:** Insurance will be done by our own means for imports. Please intimate immediately after shipment about the Airway Bill No. For indigenous items the cost must include the insurance charges.

Bill of Lading, consignment etc. to The Director, CIMFR, P.O + Dist: Dhanbad, Dhanbad, Jharkhand, India.

**46. WARRANTY:** Warranty period should be for a minimum period of **three years onsite comprehensive.**

**47. COUNTRY OF ORIGIN:** Please specify Place/County of Origin and the Place/Country from where goods will be finally shipped. These particulars are very important for establishment of Letter of Credit and arranging insurance.

**48. VALIDITY PERIOD:** Your offer should be valid for at least One Hundred Eighty (180) days from the date of opening of tenders.

49. Please also indicate names and addresses of some of the Indian Organizations to whom you have supplied material, if any, under reference.

50. This Institute is eligible for payment of concessional customs duty under OGL Scheme. Actual User-Condition (Non-industrial-R&D institution).

**51. INDIAN AGENT'S COMMISSION:** If you have any Agent in India, please indicate specifically whether the amount of agency commission payable to the agent is included in the FOB Price or not. Moreover, Indian Agent should have compulsory registration with DGS&D, Govt. of India. Please note that the tender will not be considered if the Indian Agent is not Compulsorily registered with DGS&D, Govt. of India and Agency Commission will not be paid to the Indian Agent unless a legible photocopy of DGS&D Registration Certificate duly attested is submitted to this office. The Indian Agents Commission will be paid in Indian Rupees only within thirty days from the date of commissioning and final acceptance of the whole system by CIMFR, Dhanbad-828 108, India. The role played by the Indian Agents in rendering assistance to your customers may also be specified.

**52. FREIGHT:** The mode of dispatch should be Ocean Freight/Air Freight preferably by Air India Flight and on To-Pay basis only. Please indicate the approximate Air Freight Charges for Kolkata Air Port, India. The consignments are required to be shipped by Air India (Freight to pay) up to Kolkata Airport, India. All the documents are to be made in favour of The Director, CIMFR, Dhanbad (Jharkhand) India and forwarded to our Banker.

For speedy clearance, please specify our Purchase Order Reference No. and date on the top of the parcel as well as on the Airway bill without fail. Address all the consignments to The Director, CIMFR, Dhanbad (Jharkhand) India and not to Bank. The ordered materials are being imported under Open General License.

The following documents may be sent to us directly while dispatch.

Invoice in quadruplicate with deduction of Agency Commission, if any, Packing List, Delivery Challan, Country of Origin Certificate, Literature, if any, should be enclosed.

### **53. PAYMENT TERMS :**

Term I - In case of indigenous offer, the payment will be on credit basis i.e. after receipt of material in good condition, installation, testing, commissioning, satisfactory demonstration, final acceptance of the whole system and on submission of unconditional Performance Bank Guarantee for 10% of the total order value valid till 60 days after the warranty period from a Foreign Bank duly endorsed by Nationalized Bank in India.

Term II - In case of Foreign offer, 80 percent value of goods will be paid through an Irrevocable Letter of Credit on submission of shipping documents. Balance 20 percent value of goods will be paid by Foreign Demand Draft excluding Indian Agency Commission, if any, after installation, testing, commissioning, satisfactory demonstration,

final acceptance of the whole system and on submission of unconditional Performance Bank Guarantee for 10% of the total order value valid till 60 days after the warranty period from a Foreign Bank duly endorsed by Nationalized Bank in India.

Term III - Letter of Credit / Sight Draft (For 100% payment against submission of unconditional Performance Bank Guarantee for 10% of the total order value within twenty one (21) days of the placement of Purchase Order valid till 60 days after the warranty period from a Foreign Bank duly endorsed by Nationalized Bank in India.

54. The tenders are liable to be cancelled if any of the conditions noted herein are not complied with. Hypothetical, ambiguous and conditional tenders will not be entertained at all and rejected summarily.

**55. Goods should not be dispatched until firm Purchase Order is received by the successful vendor.**

56. Director, CIMFR reserves the right to delete or alter the item given in the enclosed annexure depending on prevailing requirements.

57. Director, CIMFR reserves the right to accept or reject any tender in whole or in part thereof without assigning any reason.

### **58. Arbitration :**

Except where otherwise provided in the Contract, all questions and disputes relating to the meaning of the specifications, instructions and terms & conditions herein before mentioned and as to the quality of the materials, as to any question, claim, right, matter or thing whatsoever, in any way arising out of or relating to the Contract. Specifications, estimates, instructions, orders

or these conditions or otherwise concerning the works, or the execution of the same whether arising during the process of the work or after the completion or abandonment thereof shall be **referred to the sole arbitration of a person nominated by the Director General, Council of Scientific & Industrial Research, New Delhi**, and if he is unable or unwilling to act to the sole arbitration of some other person appointed by him willing to act as such arbitrator. The submission shall be deemed to be submission to Arbitration under the meaning of the India Arbitration & Conciliation, 1996 or any satisfactory modification or reenactment thereof for the time being in force conclusive and binding on all parties of the Contract. **The venue of the arbitration will be Dhanbad only.**

**In the case of a dispute between the purchaser and a foreign supplier, the dispute shall be settled by arbitration in accordance with provision of clause above. But if this not acceptable to the supplier then the dispute shall be settled in accordance with provisions of UNCITRAL (United Nations Commission of International Trade Law) Arbitration Rules. The venue of the arbitration shall be the place from where the order is issued.**

## SECTION - IV

### FORMATS FOR BID SUBMISSION

#### Checklist for Bid Submission

The following check-list must be filled in and submitted with the bid document:

**Technical Bid:**

1	Has the tender document issued to you?	Yes / No
2	Have you attached the technical bid form?	Yes / No
3	Have you attached a copy of the last audited balance sheet of your firm?	Yes / No
4	Have you attached proof of the manufacturer's authorization?	Yes / No
5	Have you attached the details of the income tax registration and latest income tax clearance certificate?	Yes / No
6	Have you attached the statement of deviations from the technical Specifications in the format?	Yes / No
7	Have you provided details of your maintenance infrastructure facilities including addresses of the service centers in the format?	Yes / No
8	Have you attached the technical details of the goods and services offered as a part of this bid document?	Yes / No
9	Have you attached the copies of relevant work orders executed during the last three years?	Yes / No
10	<b>Have you attached the details of identical or similar equipments supplied to other CSIR Labs/Institutes for the preceding three years together with prices eventually or finally paid?</b>	Yes / No
11	<b>Have you attached photocopy duly attested of Certificate of compulsory Enlistment of Indian Agents of foreign principals with DGS&amp;D if quoting on their behalf? Date of enlistment must be before the date of opening of tenders.</b>	Yes / No
12	Have you attached Service Provider Certificate issued by the Manufacturer?	Yes / No

## **Financial Bid:**

1	Have you attached the Financial Bid?	Yes / No
2	Have you attached the price schedule for the goods/services offered in the Format?	Yes / No
3	Have you attached the statement of deviations from the Financial terms and conditions in the format?	Yes / No

Please arrange your tender document for each part as given below:

### **Earnest Money Deposit :**

#### **TECHNICAL BID:**

##### **Technical Bid Form**

Copy of the Last Audited Balance Sheet of the company

Income Tax Registration Certificate/PAN No.and latest Income Tax Clearance Certificate

Proof of Manufacturer's authorization

Photocopy of Warranty Service Provider Agreement between the manufacturer and the Service Provider.

Statement of Deviation from the technical specifications

Details of service centers at Dhanbad

Photocopy duly attested of Certificate of compulsory enlistment of Indian Agents of foreign principals with DGS&D if quoting on their behalf. Date of enlistment must be before the date of opening of tenders?

Copies of relevant work orders

Details of supplies of identical or similar equipment made to other CSIR Labs/Institutions for the preceding three years together with price eventually or finally paid.

#### **FINANCIAL BID:**

##### **Financial Bid Form**

Estimated quantity and Financial Bid Analysis

Statement of Deviations from Financial terms and conditions

## **Technical Bid Form**

(To be submitted on the firm's Letter Head and signed by an authorized person)

To ,  
The Director  
Central Institute of Mining & Fuel Research  
P.O. DHANBAD, Barwa Road,  
DHANBAD – 826001, INDIA

**Ref: Tender No. CIMFR/PUR/14(3)2007 date: 26.09.2007**

Sir,

Having examined the bidding documents, the receipt of which is hereby duly acknowledged, we, the undersigned offer to supply and deliver goods as per the schedule of requirements and in conformity with the said bidding documents. We undertake, if our bid is accepted, to deliver the goods in accordance with the delivery schedule specified in the bidding documents.

If our bid is accepted, we will submit a unconditional performance bank guarantee for the sum equivalent to 10% of the Contract Price i.e. Total Order Value for the due performance of the Contract, in the form prescribed by the Central Institute of Mining & Fuel Research, Dhanbad.

We agree to abide by this bid for a period of One Hundred Twenty days after the date fixed for opening and it shall remain binding upon us and may be accepted at any time before the expiration of that period.

We declare that we are the manufacturers/authorized agents/distributor of

---

that we/our principals are equipped with adequate machinery for production, quality control and testing of offered products manufactured/developed and used by us.

We hereby offer to supply the Goods/Services at the price at the rates mentioned in the Financial Bid.

We enclose herewith the complete Technical Bid as required by you. This includes:

### **Technical Bid Form**

Copy of the last audited balance sheet of the company  
Proof of Manufacturers authorization.  
Technical details of the goods and services offered.  
Statement of deviation from the technical specifications  
Details of local service centers  
Product catalogues/user manual/other informative material about our products and Services.

Details of supplies of identical or similar equipment to other CSIR Labs/Institutes for the preceding three years together with prices eventually or finally paid.

Photocopy duly attested of Certificate of compulsory enlistment of Indian Agents of Foreign principals with DGS&D if quoting on their behalf. Date of enlistment (It must be before the date of opening of tenders).

We have carefully read and understood the terms and conditions of the bid document and the conditions of the contract applicable to the bid document and we do hereby undertake to supply as per these terms and conditions.

Certificate that the bidder is:

A Sole proprietorship firm and the person signing the bid document is the sole proprietor/constituted attorney of the sole proprietor, or

A partnership firm, and the person signing bid document is a partner of the firm and he has authority to refer to arbitration disputes concerning the business of the partnership by virtue of the partnership agreement/by virtue of general power of attorney, or

A company and the person signing the document is the constituted attorney.

(NOTE: Delete whatever is not applicable. All correction/deletions should invariable by duly attested by the person authorized to sign the bid document)

We do hereby undertake take, until a formal work order is prepared and executed, this bid, together with your written acceptance thereof and placement of letter of intent awarding the work order, shall constitute a binding contract between us.

Dated this day 2004 Signature of Bidder

Details of enclosures.

Full Address\_\_\_\_\_

Telephone No.\_\_\_\_\_

Telegraphic Address:\_\_\_\_\_

Fax No\_\_\_\_\_

E-Mail\_\_\_\_\_

COMPANY SEAL

**STATEMENT OF DEVIATIONS FROM TECHNICAL SPECIFICATIONS AND  
SCHEDULE OF REQUIREMENTS**

Following are the Technical deviations and variations from the Technical specifications and Schedule of Requirements. These deviations and variations are exhaustive. Except these deviations and variations, the entire work shall be performed as per your specifications and documents.

SI No.	Item	Statement of Deviations / Variations

Signature of the Bidder

Name:

Date:

Place:

Address:

Company Seal

**MAINTENANCE INFRASTRUCTURE FACILITIES INCLUDING ADDRESSES OF  
THE LOCAL SERVICES CENTRES**

LOCATION	ADDRESS OF SERVICE CENTRE	NAME OF THE CONTACT PERSON WITH TEL. No. Fax No. and Email	Total No. of qualified service engineers	Remarks

Signature of the Bidder

Name:

Date:

Place:

Address:

Company Seal

## **Financial Bid Form**

(On the Letter Head of the firm submitting the Bid Document)

To  
The Director  
Central Institute of Mining & Fuel Research  
P.O.DHANBAD, DISTT: DHANBAD  
DHANBAD-826001, INDIA

Ref: Tender No.CIMFR/PUR/14(3)2007 dated 26.09.2007

Sir,

Having examined the bidding documents and having submitted the technical bid for the same, we, the undersigned, hereby submit the Financial Bid for supply of goods and services as per the schedule of requirements and in conformity with the said bidding documents.

We hereby offer to supply the Goods/Services at the prices and rates mentioned in the Financial Bid.

We do hereby undertake that, in the event of acceptance of our bid, the supply of Goods/Services shall be made as stipulated in the schedule to the Bid document and that we shall perform all the incidental services.

The prices quoted are inclusive of all charges including installation and commissioning charges in the Central Institute of Mining & Fuel Research Institute, Dhanbad.

We enclose herewith the complete Financial Bid as required by you. This includes:

Financial Bid Letter

Price Schedule

Statement of deviations from Financial terms and conditions.

We agree to abide by our offer for a period of One Hundred Twenty (120) days from the date fixed for opening of the bid documents and that we shall remain bound by a communication of acceptance within that time.

We have carefully read and understood the terms and condition of the bid document and we do hereby undertake to supply as per these terms and conditions. The Financial Deviation are only those mentioned in the statement of deviation from financial terms and conditions.

Certified that the bidder is:

A sole proprietorship firm and the person signing the bid document is the sole proprietor/constituted attorney of sole proprietor.

Or

A partnership firm and the person signing the bid document is a partner of the firm and he has authority to refer to arbitration disputes concerning the business of the partnership by virtue of the partnership agreement/by virtue of general power of attorney.

Or

A company and signing the bid document is the constituted attorney.

(Note: Delete whatever is not applicable. All corrections/deletions should invariably be duly attested by the person authorized to sign the bid document).

We do hereby undertake, that until a formal work order is prepared and executed, this bid, together with your written acceptance thereof and placement of letter of intent awarding the work order, shall constitute a binding contract between us.

Dated this day of \_\_\_\_\_ 2007 Signature of Bidder

Details of enclosures

Full Address:  
Telephone No.  
Telegraphic Address:  
E-mail:

COMPANY SEAL

### PRICE SCHEDULE - Estimated Quantity and Financial Bid Analysis

Sl No	Item Name	Qty.	Manufacturer	Model Name & Version	Compliance to suggested Technical Specification	Operating System Environment	Unit Cost Rs.	Total cost (inclusive of all other charges)

1. Attach sheet giving detailed Technical Specification and deviations for the suggested systems.

**NOTE**

- (i) For Financial bid comparison total Value in Col. No. 9 shall be the basis.
- (ii) Unit value quoted in actual quantity of work shall form the basis.
- (iii) The Bid should have Col. 3 x Col. 8 = Col.9. Any error in the Table of any bidder is liable to be out rightly rejected.
- (iv) The price quoted should be inclusive of all charges including all applicable taxes, Octroi, freight and handling charges, and all other miscellaneous expenses.
- (v) In case of discrepancy between unit price and total price, the unit price will prevail.
- (vi) Annual Maintenance Charges after warranty period should be quoted separately.

Signature of the bidder

Name :

Place :

Date :

Address :

Company Seal

### **STATEMENT OF FINANCIAL DEVIATIONS**

Following are the financial deviations and variation(s) from the exceptions to the specifications and documents for the Bid document. These deviation(s) and variation(s) are exhaustive.

Except these deviation(s) and variation(s), the entire work shall be performed as per your specifications and documents.

<b>Sl No.</b>	<b>Section No.</b>	<b>Clause No.</b>	<b>Statement of Deviations / Variations</b>

S. No. Section No. Clause No. Statement of deviation(s) and variation(s)

Signature of the bidder

Name:

Place:

Date:

Address:

Company Seal

**BID SECURITY FORM**

WHEREAS .....  
(hereinafter called "the Bidder") has submitted its bid dated .....(Date if  
submission of bid) for the supply of .....(Name and/or  
description of the goods) (Hereinafter called "the bid").

KNOW ALL PEOPLE by these presents that WE  
.....(Name of bank) of .....  
(Name of country), having our registered office at (address & phone & fax no. of bank)  
(hereinafter called "the bank"), are bound unto ..... (Name of  
Purchaser) (hereinafter called "the Purchaser") in the sum of  
..... For which payment well and truly to be made  
to the said purchaser, the Bank binds itself, its successors, and assigns by these presents, Sealed  
with the common Seal of the said Bank this ..... Day of  
..... 200.....

THE CONDITIONS of this obligation are:

1. If the Bidder withdraws its Bid during the period of bid validity specified by the Bidder on the Bid Form; or
2. If the Bidder, having been notified of the acceptance of its bid by the Purchaser During the period of bid validity:
  - a) Fails or refuses to execute the Contract Form if required; or
  - b) Fails or refuses to furnish the performance security, in accordance with Instruction to Bidders.

We undertake to pay the purchaser up to the above amount upon receipt of its first written demand, without the Purchaser having to substantiate its demand, provided that in its demand the Purchaser will note that the amount claimed by it is owing to it, owing to the occurrence or one or both of the two conditions, specifying the occurred condition or conditions.

This guarantee shall remain in force up to and including Forty-five (45) days after the period of the bid validity, and any demand in respect thereof should reach the Bank not later than the above date.

**PERFORMANCE SECURITY FORM**

To: \_\_\_\_\_ (Name of Purchaser)  
WHEREAS \_\_\_\_\_ (Name of Supplier) hereinafter called "the Supplier" has undertaken, in pursuance of Contract No. \_\_\_\_\_ dated \_\_\_\_\_ 2007 to supply \_\_\_\_\_ (Description of Goods and Services) hereinafter called "the Order" AND WHEREAS it has been stipulated by you in the said order that the Supplier shall furnish you with a Bank Guarantee by a recognized bank for the sum specified therein as security for compliance with the Supplier's performance obligations in accordance with the order.

AND WHEREAS we have agreed to give the Supplier a Guarantee:  
THEREFORE WE hereby affirm that we are Guarantors and responsible to you, on behalf of the Supplier, up to a total of \_\_\_\_\_ (Amount of the Guarantee in Words and Figures) and we undertake to pay you, upon your first written demand declaring the sum or sums within the limit of \_\_\_\_\_ (Amount Guarantee) as aforesaid, without your needing to prove or to show grounds or reasons for your demand or the sum specified therein.

This guarantee is valid until the \_\_\_\_\_ day of \_\_\_\_\_ 2007

**Signature and Seal of Guarantors**

Date

**Address**

All correspondence with reference to this guarantee shall be made at the following address:

\_\_\_\_\_  
\_\_\_\_\_  
\_\_\_\_\_

(Name & address of the lab)

\*\*\*\*\*